

- NOTES:
1. RATED LIFTING CAPACITY: 165,000 LBS (75MT)
 2. RATED CAPACITY ASSUMES Z-9067 IS IN GOOD AS SOLD CONDITION AND REQUIRES SERVICE INSPECTION AND PROOF LOAD
 3. SHOWN WITH AIRCRAFT 50X20X20 (32PR) TIRES AND JOHN DEERE 4.5L ENGINE
 4. SHOWN WITH (4) 12" X 34' NYLON 2-PLY SLING SETS
 5. ORIGINAL Z-9067 ICH WAS 22'-0"
 6. ORIGINAL Z-9067 ICW WAS 21'-0"
 7. SHOWN WITH 2'-0" COLUMN EXTENSIONS (CUSTOMER TO CONFIRM)
 8. SHOWN WITH 1'-0" TOP BEAM EXTENSION (CUSTOMER TO CONFIRM)
 9. FOR RECOMMENDED PIER INFORMATION CONSULT OUR LAUNCHING PIERS DATA SHEET

- Z-9067 OPTIONS (AS SOLD):
1. 2-SPEED HOISTS
 2. WIRELESS REMOTE CONTROL
 3. TOP BEAM FLANGE

CUSTOMER SIGNATURE _____ PRINTED NAME _____ DATE _____
 DEALER SIGNATURE _____ PRINTED NAME _____ DATE _____

THIS DOCUMENT MAY CONTAIN CONFIDENTIAL, PRIVILEGED OR PROPRIETARY INFORMATION AND IS INTENDED SOLELY FOR THE USE OF THE INDIVIDUAL, GROUP OR ENTITY TO WHOM IT IS ADDRESSED AND MUST NOT BE SHARED WITH THIRD PARTIES WITHOUT THE WRITTEN CONSENT OF MARINE TRAVELIFT INC. THE CONTENT OF THIS DOCUMENT IS FOR INFORMATIONAL PURPOSES ONLY AND DOES NOT REPRESENT A CONTRACT OR ENGAGEMENT OF ANY SORT. IF YOU ARE NOT THE INTENDED RECIPIENT YOU ARE NOTIFIED THAT DISCLOSING, COPYING, DISTRIBUTING OR TAKING ANY ACTION IN RELIANCE ON THE CONTENTS OF THIS INFORMATION IS STRICTLY PROHIBITED.

THIS DOCUMENT AND THE INFORMATION CONTAINED HEREIN IS THE PROPERTY OF MARINE TRAVELIFT INC. AND SHALL NOT BE DISCLOSED OR USED BY A RECIPIENT EXCEPT AS SPECIFICALLY AUTHORIZED BY MARINE TRAVELIFT INC.

PROJECT NUMBER
126-0384
 MODEL
Z-9067
 TYPE
GENERAL ARRANGEMENT
 ORDER NUMBER
Z-9067

LATEST REVISION DESCRIPTION
INITIAL RELEASE

ALL DIMENSIONS ARE NOMINAL		
NAME	DATE	SCALE
DRAWN	TWK 7/14/2021	NS
REVISED	TWK 7/14/2021	1 OF 2
APPROVED		1302083KJ

PRELIMINARY

MARINE TRAVELIFT SHUTTLELIFT
 49 EAST YEW STREET STURGEON BAY, WI 54235

MODEL & DESCRIPTION **BOATHOIST - 75BFMII**
BERTHON BOAT CO.
 DRAWING NUMBER
1302083KJ

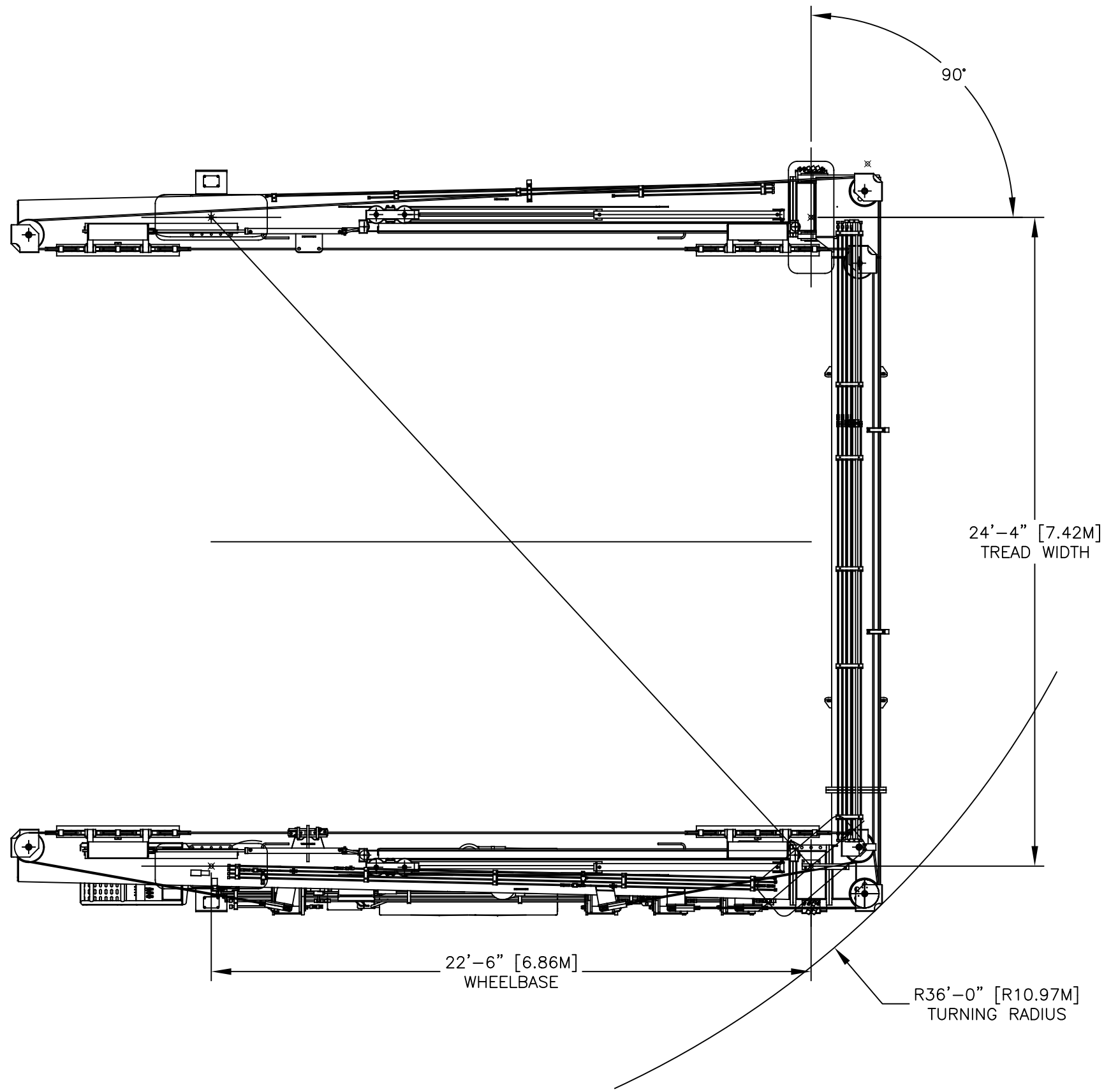

PRELIMINARY

ALL DIMENSIONS ARE NOMINAL THIS DOCUMENT AND THE INFORMATION CONTAINED HEREIN IS THE PROPERTY OF MARINE TRAVELIFT INC. AND SHALL NOT BE DISCLOSED OR USED BY A RECIPIENT EXCEPT AS SPECIFICALLY AUTHORIZED BY MARINE TRAVELIFT INC.	SIZE B		
	DESCRIPTION BERTHON BOAT CO.		
SCALE NS	SHEET 2 OF 2	DRAWING NUMBER 1302083KJ	